



LUMiCHARGER LP 1

Separately located electric charger that operates autonomously, that can operate autonomously or with the SEAK SMART CITY control system, allowing it to determine the available capacity for charging cars. During the day, public lighting is in standby mode under electrical voltage and the entire capacity is available for cars. At night, part of the capacity is used for lighting and the rest for cars. Intelligent lighting control (at times and in places where 100% intensity is not needed throughout the night) further increases the maximum power we can provide for vehicle charging.

Features

- ✓ Compatible with SEAK SMART CITY lighting control
- ✓ Operating states indicated by a change in the color of the light of the integrated lamp section
- ✓ OCPP 1.6/J support
- ✓ Payment via [chargeme.online](https://www.chargeme.online)

Technical specification

Electrical properties:

| | |
|---------------------|----------------------------|
| Power supply | 3xAC 230V, 32A, 50Hz, TN-S |
| Max. output power | 22 kW |
| Max. output current | 3x32 A |
| Own consumption | max. 11W |
| Charging connector | Type 2 standard: 32A/400V |

Communication:

| | |
|-----------|---|
| Powerline | 2-way powerline QM-50-SSI3, (asynchro) |
| RS485 | Yes |
| LAN | - |
| WiFi | - |
| GSM | - |
| RFID | MIFARE card/tag according to ISO14443 (13.56 MHz) |

Safety:

| | |
|-----------------------------|---------------------------|
| Protection class | I. |
| Protection type | IP 65 |
| Impact resistance | IK10 (post), IK06 (shade) |
| Protection against overload | circuit breakers 32A |
| Leakage current sensor RCD | 30mA AC, 6mA DC |
| Operating temperature | -25 °C ~ +50 °C |
| Storage temperature | -40 °C ~ +80 °C |
| Operating humidity air | max. 90% non-condensing |

Mechanical specifications:

| | |
|-----------|-----------------|
| Weight | 13kg |
| Dimension | 1335x150mm |
| Material | aluminium alloy |

Dimensions:

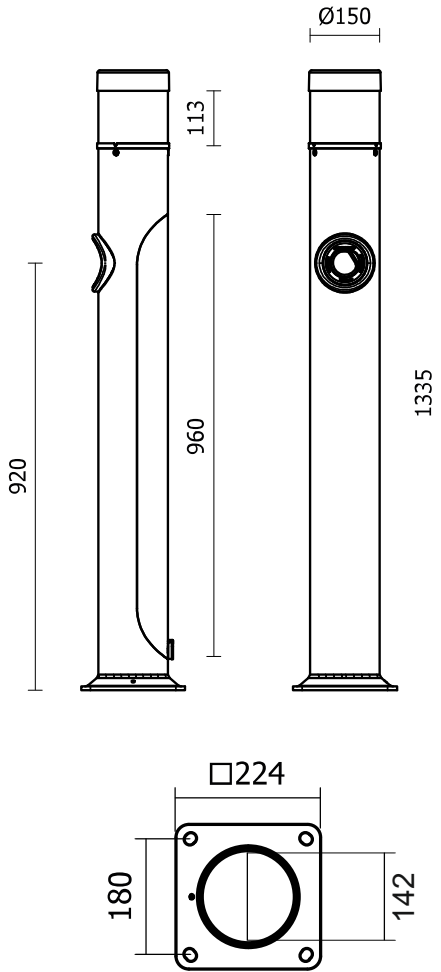

Accessories:

Concrete base

Ord. code: CBLP1



Base grate

Ord. code: BGLP1



Color variants - ordering codes

Powerline communication:

- Black - LMCHLP1PLBK
 - Grey - LMCHLP1PLGY
 - Inox - LMCHLP1PLIN
 - Other color - LMCHLP1PLOT
- (Please indicate in the order notes.)

RS485 communication:

- Black - LMCHLP1RSBK
 - Grey - LMCHLP1RSGY
 - Inox - LMCHLP1RSIN
 - Other color - LMCHLP1RSOT
- (Please indicate in the order notes.)

Basic colors



Other colors (please indicate in the order notes)

