

Instructions for use

LUMiCHARGER S2S

ver. 122025



Content

1 Safety precautions	3
2 Technical specification	4
3 Installation	5
4 Charging	7

1 Safety precautions

- Before installing, servicing, or using the charging station, read and follow these safety precautions.
- Installation may only be carried out by persons with appropriate qualifications in electrical engineering.
- The charging station must be installed in accordance with the relevant standards for each country and local regulations.
- In the event of a malfunction, the user is not authorized to open, disassemble, repair, or otherwise modify the device.
- The device may only be opened for the purpose of connecting or disconnecting it from the electrical network.
- If repair is necessary, contact SEAK s.r.o. or your dealer.
- The charging station includes an RCD-A-EV residual current device, so there is no need to install a separate one.
- The charging station is designed only for charging electric vehicles that support the IEC 62196-1 and IEC 61851-1 standards. Do not use it for other purposes or with other vehicles or objects.
- Do not use the charging station in combination with sockets that are not rated for the required current load.
- Do not use the charging station if it is faulty or damaged, or if the display indicates an error.
- A product exposed to direct sunlight may overheat and consequently limit or stop charging until the internal components cool down to operating temperature.
- Do not use the charging station in heavy rain.
- Do not touch the terminals with sharp metal objects such as wires, needles, or other tools.
- Before charging, always check that the charging station, charging cable, and connector are not damaged.
- Ensure that the charging cable does not obstruct pedestrians, other vehicles, or other objects.
- Take precautions to prevent the charging plug from coming into contact with heat sources, dirt, or water.

2 Technical specification

Electrical properties:

Voltage	3x AC 230/400V, 63A, 50Hz, TN-S
Own consumption	max. 10W
Max. output current	2x (3x32 A)
Max. output power	44 kW (2x22 kW)
Charging connector	Type 2 standard: 32A/400V

Communication:

Powerline	2-way powerline QM-50-SSI3 (asynchro)
RS485	Yes
LAN	-
WiFi	-
GSM	-
RFID	MIFARE card/tag according to ISO14443 (13.56 MHz)

Safety:

Protection class	I.
Protection type	IP 54
Impact resistance	IK10
Overload protection	coils CT
Operating temperature	-25 °C ~ +50 °C
Storage temperature	-40 °C ~ +80 °C
Operating air humidity	max. 90% without condensation

Mechanical specifications:

Weight	25kg
Dimensions	1300x200x150mm
Material	Stainless steel
Color	White

3 Installation

Working on electrical installations without proper safety precautions will result in the risk of electric shock, leading to serious injury or death. Installation must only be carried out by qualified personnel. If possible, place the charging station in an environment where it is not exposed to extreme sunlight and where there is no possibility of external damage.

Preparation for installation:

- Before starting installation work, check that the power cable is disconnected and secured against being reconnected.
- Place the rubber leveling pad included in the package under the charging station.
- Open the mounting door on the back of the charging station. .
- Pull the power cables through the opening on the bottom of the charger. We recommend placing the separate charger on its own base, as shown in the following illustration.

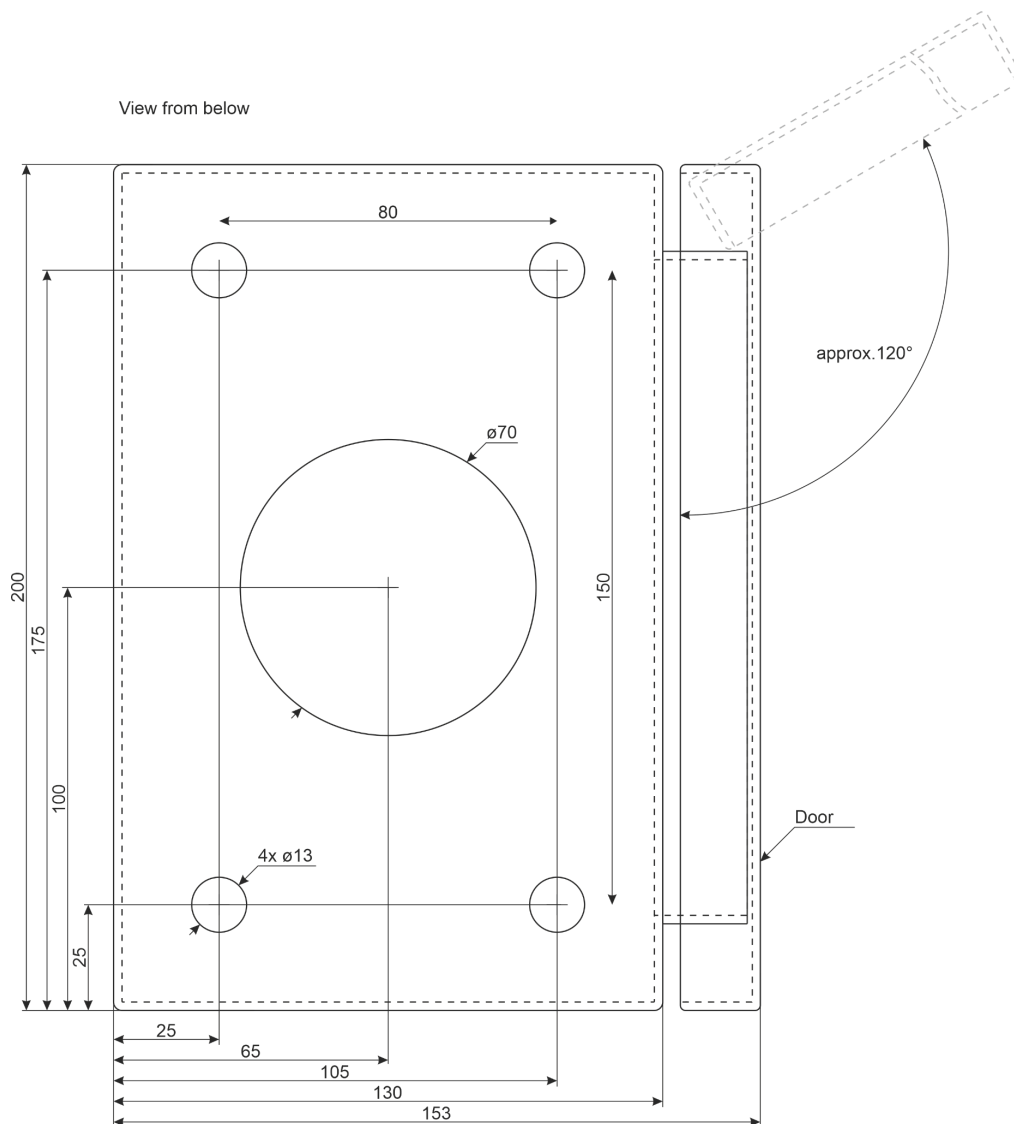

Electrical connection:

- The electrical connection should be routed through a prepared concrete base with sufficient reserve for connecting the charger.
- The electrical wiring with EV chargers must be equipped with suitable circuit breakers and a residual current device.
- Make sure that the main power switch for the charging station is turned off. Check the voltage to make sure that the electrical cables are not live.

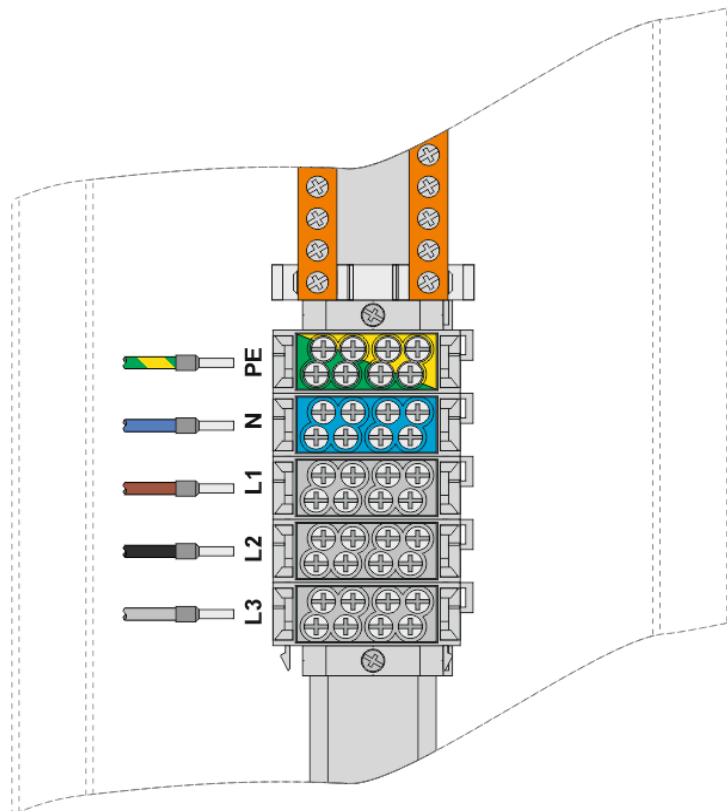

- A 3F + N + PE cable is used for installation; the use of shielded cables is optional or required by local laws. Optional cable shielding must be attached to the PE rail at both ends of the cable. Shorten the connecting wires to a suitable length (as short as possible). The PE protective conductor must be longer than the other conductors.
- Check that both the external cabling and internal wires are correctly connected to the front cover.
- The internal cabling must not be excessively compressed or bent.
- After checking, close and lock the service door and put the charging station into operation.
- Before commissioning, all construction work must be completed, including the installation and connection of the charger. The owner of the charging station is obliged to ensure that the charger is inspected in accordance with applicable legislation. The professional inspection is carried out by persons with professional

competence to inspect electrical equipment with qualifications in accordance with STN 33 1500 and Act 508/2009.

4 Charging



Connect charging cable to the car.













Use your RFID card, scan the QR code with your phone, or open chargeme.online on your phone.



Charging starts after RFID authentication. After logging into the app, start charging.

After connecting the car to the charging station, the LED light indicates the following charging statuses:

CHARGING STATUS	
Light colour	Status
 Green	Ready for charging
 Green flashing	Vehicle connected
 Green-blue flashing	Authorisation in progress
 Blue flashing	Starting to charge
 Blue	Charging
 White	Charging finished
 White flashing	RFID user logged out and socket is unlocked
 Orange	RFID authorization failed
 Purple	Current capacity exceeded - authorize to queue
 Purple flashing	Authorized, waiting for free capacity to charge
 Red	Error/Charging disabled